

Switching Regulator Valve Cutaway

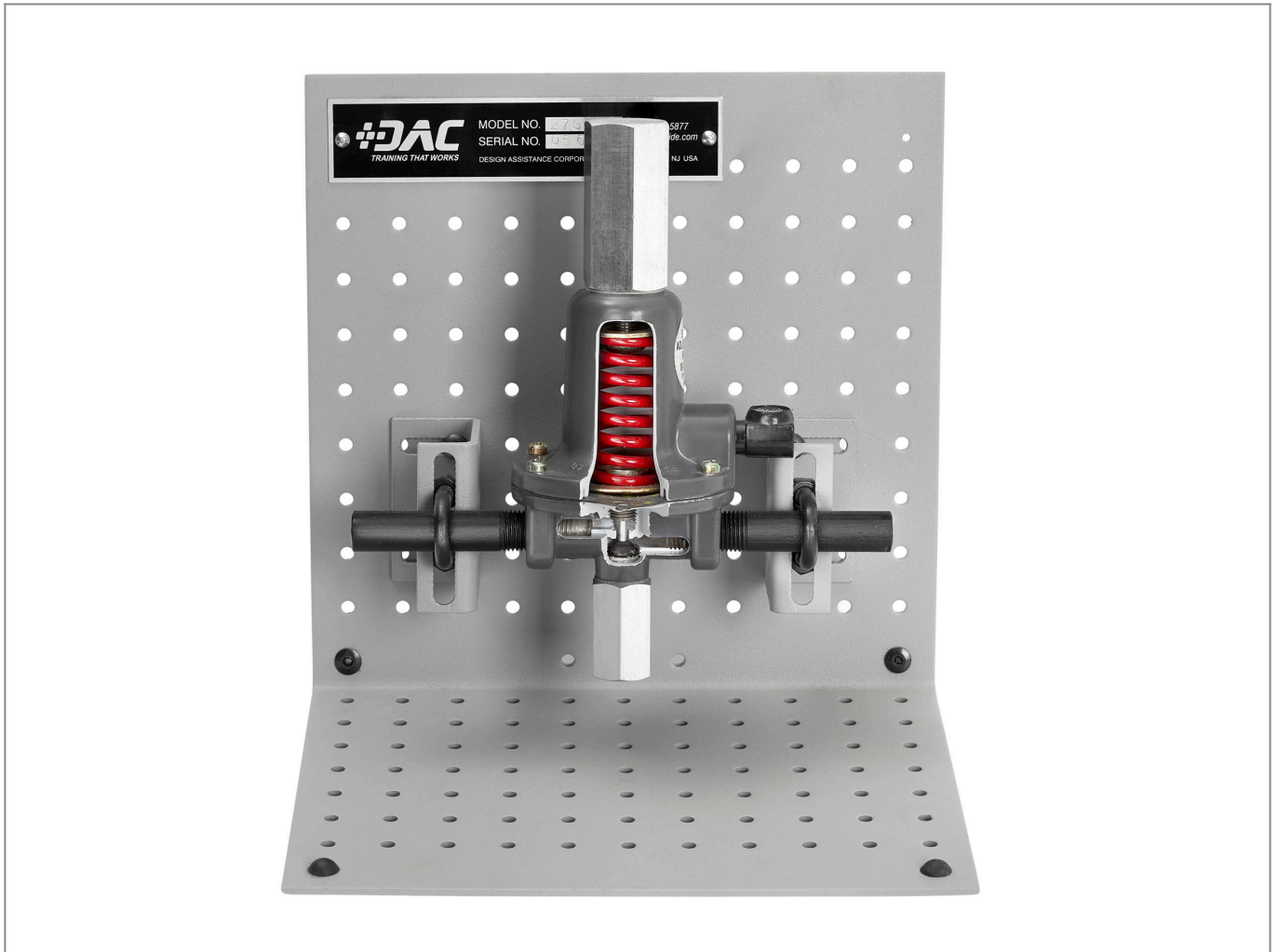

Model: 273-217

DAC Worldwide's Switching Regulator Valve Cutaway (273-217) is a detailed specialty pressure regulator cutaway that depicts a common industrial switching-type pressure regulator commonly found in refineries, petro-chemical plants, oil and gas applications, and other industrial, commercial and manufacturing environments.

These unique regulators, often incorporated into pneumatic control valve circuits, perform switching applications relating to venting, on/off control, and failure/lock-up modes. Considering their common safety-related applications, knowledge of their operating principles and applications is vital to maintenance and operations personnel.

The Switching Regulator Valve Cutaway is mounted on a powder-coated, formed-steel mounting assembly, allowing for standalone display, bench-top mounting, or mounting on related DAC Worldwide mounting benches and display structures.

Through careful sectioning, the complete internal flow paths and active components of the regulator can be seen, while also allowing for disassembly for more complete inspection. All primary features have been retained and are showcased through strategic sectioning.

FEATURES & SPECIFICATIONS

- Sectioning of actual industrial component.
- Common 1/4" -1/2" NPS component brands and models from leading US manufacturers are chosen for industrial training relevancy.
- Cleaning, priming, and painting using a high-durability polyurethane coating.
- All internal components, including control spring, adjusting screw, diaphragm, stem, o-rings, diaphragm head, disk, disk holder, and all porting, shown.
- 13-gauge, formed-steel, powder-coated mounting stand with component attachment brackets and threaded steel pipe mounting spools.
- Provision for mounting on related DAC Worldwide bench, workstation, and display products.
- Original equipment manufacturer's installation, operation, and maintenance manual.
- Packaging for shipment via parcel service.

PRODUCT DIMENSIONS

- **Product Dimensions**
(LxWxH)
9" x 9" x 10"(230 x 230 x 250 mm)
- **Shipping Dimensions**
(LxWxH)
12" x 12" x 12"(305 x 305 x 305 mm)

OPTIONS

- Recommended #902V - Mobile Display Stand

Address

DAC Worldwide
3 Killdeer Court, Suite #301
Swedesboro, NJ 08085

Contacts

email: contact@dacworldwide.com
phone: (800) 662 5877